

# PR 750

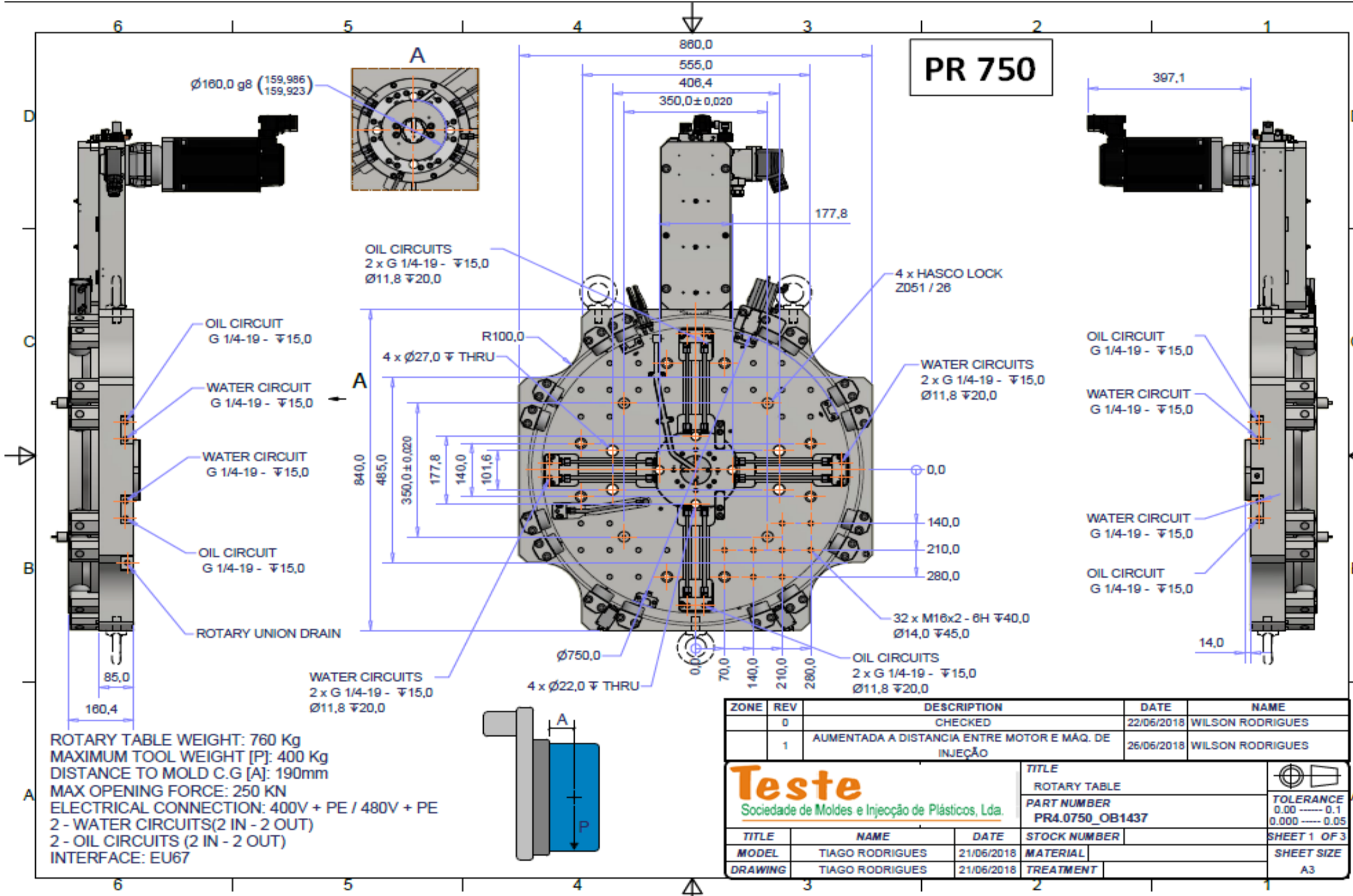

ROTARY TABLE WEIGHT: 760 Kg  
 MAXIMUM TOOL WEIGHT [P]: 400 Kg  
 DISTANCE TO MOLD C.G. [A]: 190mm  
 MAX OPENING FORCE: 250 KN  
 ELECTRICAL CONNECTION: 400V + PE / 480V + PE  
 2 - WATER CIRCUITS(2 IN - 2 OUT)  
 2 - OIL CIRCUITS (2 IN - 2 OUT)  
 INTERFACE: EU67

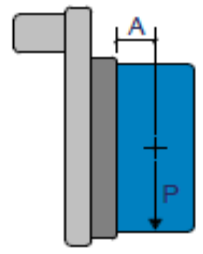

ZONE	REV	DESCRIPTION	DATE	NAME
	0	CHECKED	22/06/2018	WILSON RODRIGUES
	1	AUMENTADA A DISTANCIA ENTRE MOTOR E MAQ. DE INJECAO	26/06/2018	WILSON RODRIGUES

  

<b>Teste</b>		TITLE		TOLERANCE 0.00 ----- 0.1 0.000 ----- 0.05
Sociedade de Moldes e Injecao de Plasticos, Lda.		ROTARY TABLE		
TITLE		PART NUMBER		SHEET 1 OF 3
ROTARY TABLE		PR4.0750_OB1437		
MODEL	TIAGO RODRIGUES	DATE	21/06/2018	MATERIAL
DRAWING	TIAGO RODRIGUES	DATE	21/06/2018	TREATMENT
				SHEET SIZE A3

# NEGRI BOSSI V250 T

PR 750

Pág. 2

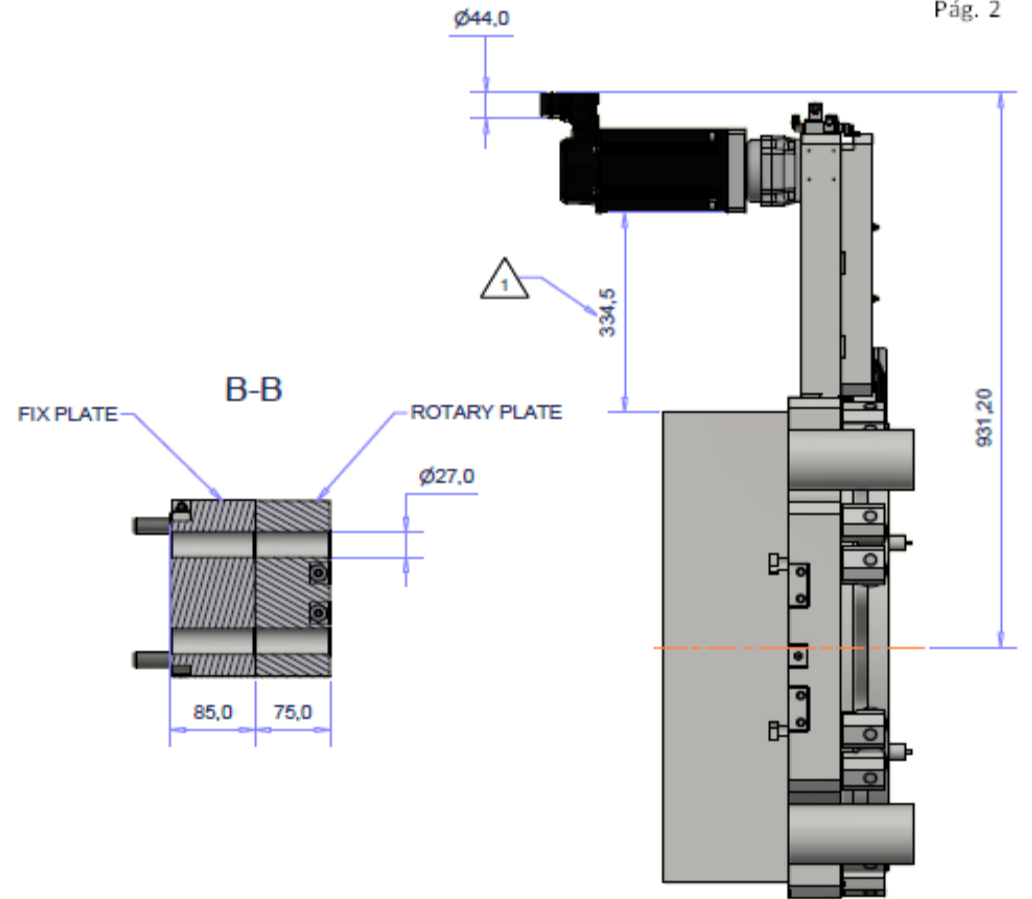
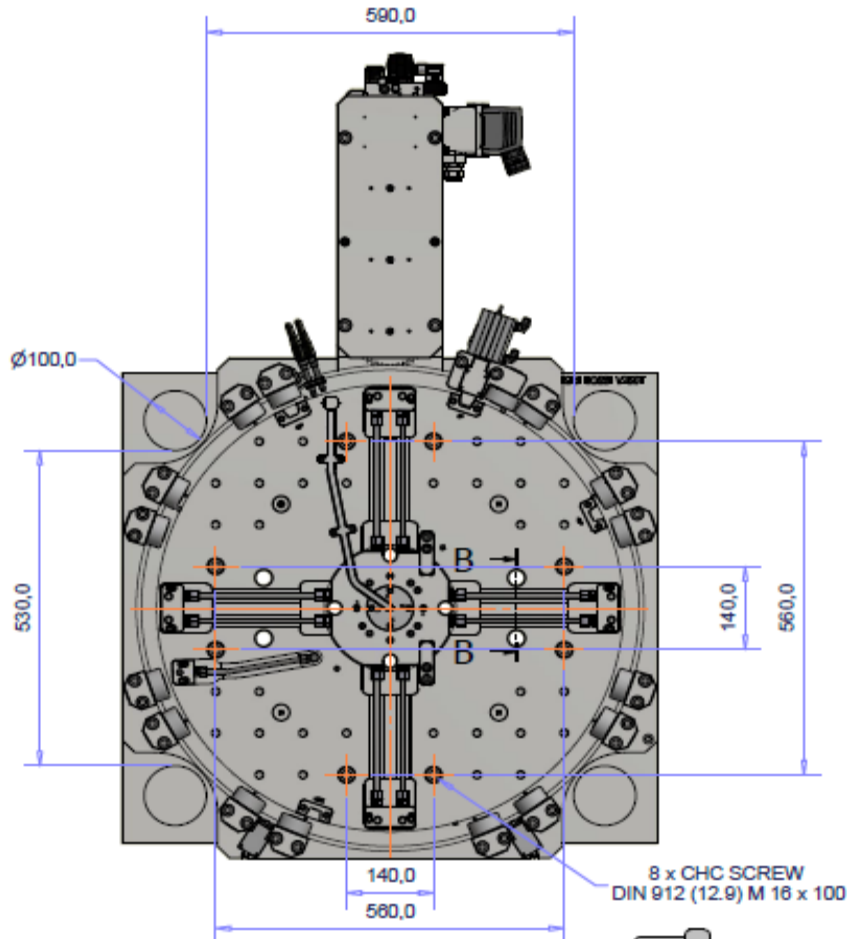

ROTARY TABLE WEIGHT: 760 Kg  
 MAXIMUM TOOL WEIGHT [P]: 1340 Kg  
 DISTANCE TO MOLD C.G [A]: 190mm  
 MAX OPENING FORCE: 250 KN  
 ELECTRICAL CONNECTION: 400V + PE / 480V + PE  
 2 - WATER CIRCUITS(2 IN - 2 OUT)  
 2 - OIL CIRCUITS (2 IN - 2 OUT)  
 INTERFACE: EU67

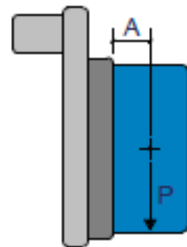

ZONE	REV	DESCRIPTION	DATE	NAME
	0	CHECKED	22/06/2018	WILSON RODRIGUES
	1	AUMENTADA A DISTANCIA ENTRE MOTOR E MÁQ. DE INJEÇÃO	26/06/2018	WILSON RODRIGUES

  

<b>Teste</b> Sociedade de Moldes e Injeção de Plásticos, Lda.			TITLE ROTARY TABLE		TOLERANCE 0.00 ----- 0.1 0.000 ----- 0.05
			PART NUMBER PR4.0750_OB1437		
TITLE	NAME	DATE	STOCK NUMBER	SHEET 2 OF 3	
MODEL	TIAGO RODRIGUES	21/06/2018	MATERIAL	SHEET SIZE	
DRAWING	TIAGO RODRIGUES	21/06/2018	TREATMENT	A3	

ROTARY TABLE WEIGHT: 760 Kg  
 MAXIMUM TOOL WEIGHT [P]: 400 Kg  
 DISTANCE TO MOLD C.G [A]: 190mm  
 MAX OPENING FORCE: 250 kN  
 ELECTRICAL CONNECTION: 400V + PE / 480V + PE  
 2 - WATER CIRCUITS (2 IN - 2 OUT)  
 2 - OIL CIRCUITS (2 IN - 2 OUT)  
 INTERFACE: EU87

PR 750

Pág. 3

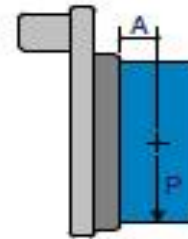

EYEBOLT HOLE  
 M20x2.5 - 6H  $\nabla$ 50,0  
 $\varnothing$ 17,5  $\nabla$ 55,0

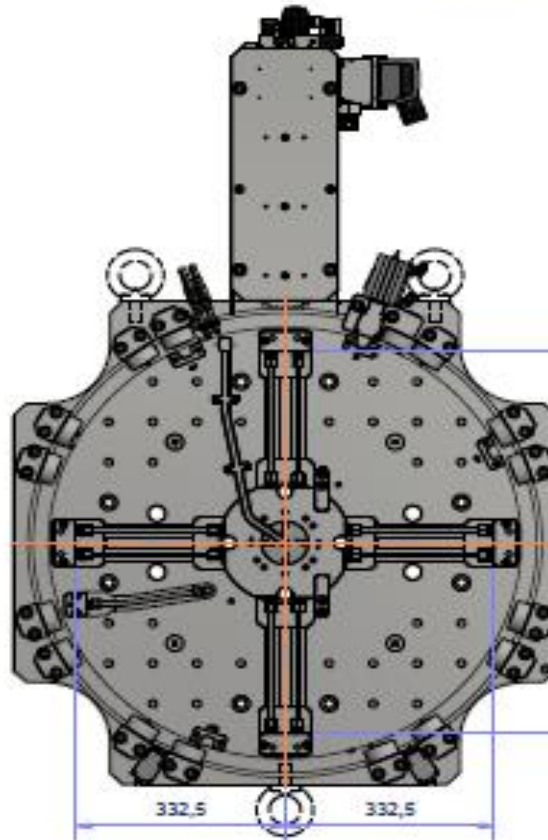

EYEBOLT HOLE  
 2 x M20x2.5 - 6H  $\nabla$ 45,0  
 $\varnothing$ 17,5  $\nabla$ 50,0

EYEBOLT HOLE  
 2 x M20x2.5 - 6H  $\nabla$ 45,0  
 $\varnothing$ 17,5  $\nabla$ 50,0

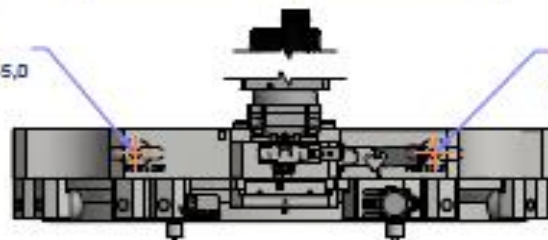

ZONE	REV	DESCRIPTION	DATE	NAME
	0	CHECKED	22/08/2018	WILSON RODRIGUES
	1	ALIMENTADA A DISTANCIA ENTRE MOTOR E MAQ. DE INEÇÃO	28/08/2018	WILSON RODRIGUES

**Teste**

Sociedade de Moldes e Injeção de Plásticos, Lda.

TITLE	NAME	DATE	STOCK NUMBER	SHEET 3 OF 3
ROTARY TABLE <td>TIAGO RODRIGUES</td> <td>21/08/2018</td> <td></td> <td></td>	TIAGO RODRIGUES	21/08/2018		
PART NUMBER				
PR4.0750_OB1437				
MATERIAL				
TREATMENT				



TOLERANCE  
0.05 - 0.1  
0.005 - 0.05

SHEET SIZE

A3